

# V20EH Open-Center Directional Control Valve

Mobile Hydraulic Valves  
Catalog HY14-2733/US

aerospace  
climate control  
electromechanical  
filtration  
fluid & gas handling  
**hydraulics**  
pneumatics  
process control  
sealing & shielding



ENGINEERING YOUR SUCCESS.

**WARNING – USER RESPONSIBILITY**

FAILURE OR IMPROPER SELECTION OR IMPROPER USE OF THE PRODUCTS DESCRIBED HEREIN OR RELATED ITEMS CAN CAUSE DEATH, PERSONAL INJURY AND PROPERTY DAMAGE.

- This document and other information from Parker-Hannifin Corporation, its subsidiaries and authorized distributors provide product or system options for further investigation by users having technical expertise.
- The user, through its own analysis and testing, is solely responsible for making the final selection of the system and components and assuring that all performance, endurance, maintenance, safety and warning requirements of the application are met. The user must analyze all aspects of the application, follow applicable industry standards, and follow the information concerning the product in the current product catalog and in any other materials provided from Parker or its subsidiaries or authorized distributors.
- To the extent that Parker or its subsidiaries or authorized distributors provide component or system options based upon data or specifications provided by the user, the user is responsible for determining that such data and specifications are suitable and sufficient for all applications and reasonably foreseeable uses of the components or systems.

**OFFER OF SALE**

The items described in this document are hereby offered for sale by Parker-Hannifin Corporation, its subsidiaries or its authorized distributors. This offer and its acceptance are governed by the provisions stated in the detailed "Offer of Sale" elsewhere in this document or available at [www.parker.com/hydraulicvalve](http://www.parker.com/hydraulicvalve).

**SAFETY GUIDE**

For safety information, see Safety Guide SG HY14-1000 at [www.parker.com/safety](http://www.parker.com/safety) or call 1-800-CParker.

© Copyright 2008, Parker Hannifin Corporation, All Rights Reserved

Cat HY14-2733.indd, dd



---

**Technical Information**

General Description..... 1

Operation..... 1, 13

Benefits ..... 2

Assembly Callout Drawing..... 2

Specifications ..... 3

Weights..... 3

Connections ..... 3

Dimensions..... 4

Schematic..... 4

**Ordering Information**

Inlet ..... 5

Outlet ..... 6

Utility Section..... 7

Work Section, Standard..... 8

Work Section, Handle Override ..... 9

Work Section, Single Sided..... 10

Mid-Inlets..... 11

V20 Solenoids ..... 12

V20 Accessories..... 12

**Installation Information**

EH-P Sheet (Sample)..... 14

EH-P Sheet ..... 15

**Terms of Sale with Warranty Limitations..... 16**

**Safety Guide ..... 17 - 18**

## General Description

The V20 has been a strong and reliable player in the 75-100 LPM (20-26 GPM) open-center, directional control valve market for many years. Now it has a new, electrohydraulic package designed for open-center systems and for those customers wanting to take machine control to the next level.

The offering consists of the following:

- A global solenoid (pwm) that can be used for proportional or on/off control. The coils have a molded on Amp Jr. or Deutsch connector.
- Work sections rated to 240 Bar (3500 PSI): 4-way, 3-position; and 3-way, 3-position.
- A pilot generating/regulating section that is referred to as a “utility section”. The purpose of this section is to generate and regulate pilot pressure in an open-center circuit. This section is to be placed adjacent to the outlet cover.



**Solenoid (1 piece)**

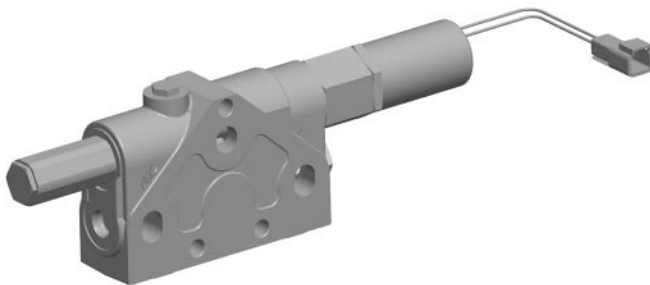

**Utility Section**

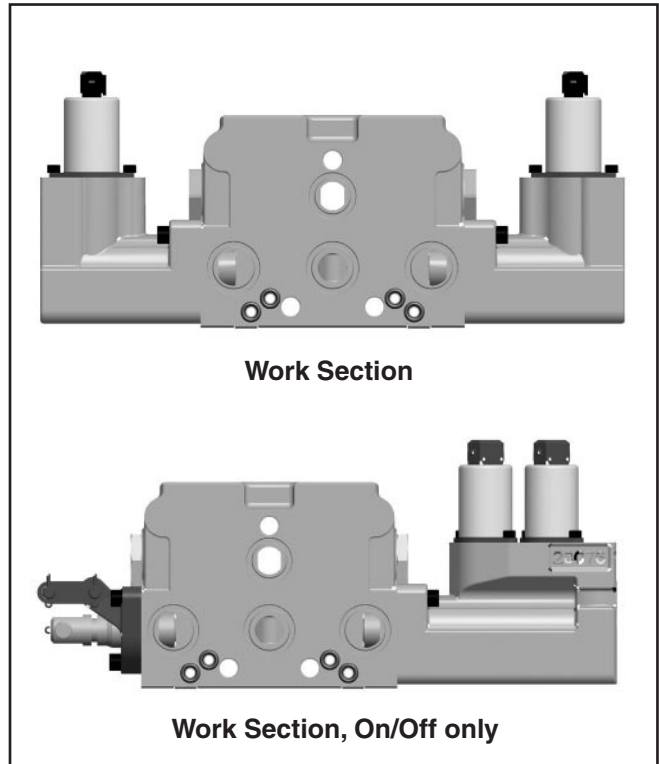

**Work Section**

**Work Section, On/Off only**

## Operation

Open-center valves that are operated by either hydraulic-remotes or electrohydraulics require a way to generate and regulate the pilot pressure. For hydraulic-remote operation, the regulated pilot pressure is needed for the pilot controllers. For electrohydraulic operation, the regulated pilot pressure is required for the work section solenoids. Generation and regulation of the pilot signal can be accomplished externally with an in-line solution, however, this approach requires extra plumbing.

The V20 has an integrated section that selectively generates and regulates the pilot pressure to be sent to the hydraulic-remote controllers, or the solenoids installed in the work section.

When an operator selects a spool, a signal is sent to a normally open solenoid in the “utility” section. Pressure will then build until it reaches the setting of the buildup cartridge. This is sufficient pressure to move the main spool, so that it can be connected to the load pressure. At that point, the inlet of the valve will see system pressure, and the pressure-reducing valve in the “utility section” will regulate the pilot pressure to the hydraulic-remote controllers or the work section solenoids.

For electrohydraulic operation, optimizing machine control is achieved by having a dedicated drain for the work section solenoids. Therefore, the V20EH package isolates the solenoid within the control valve, and the solenoid drain port is located in the inlet.

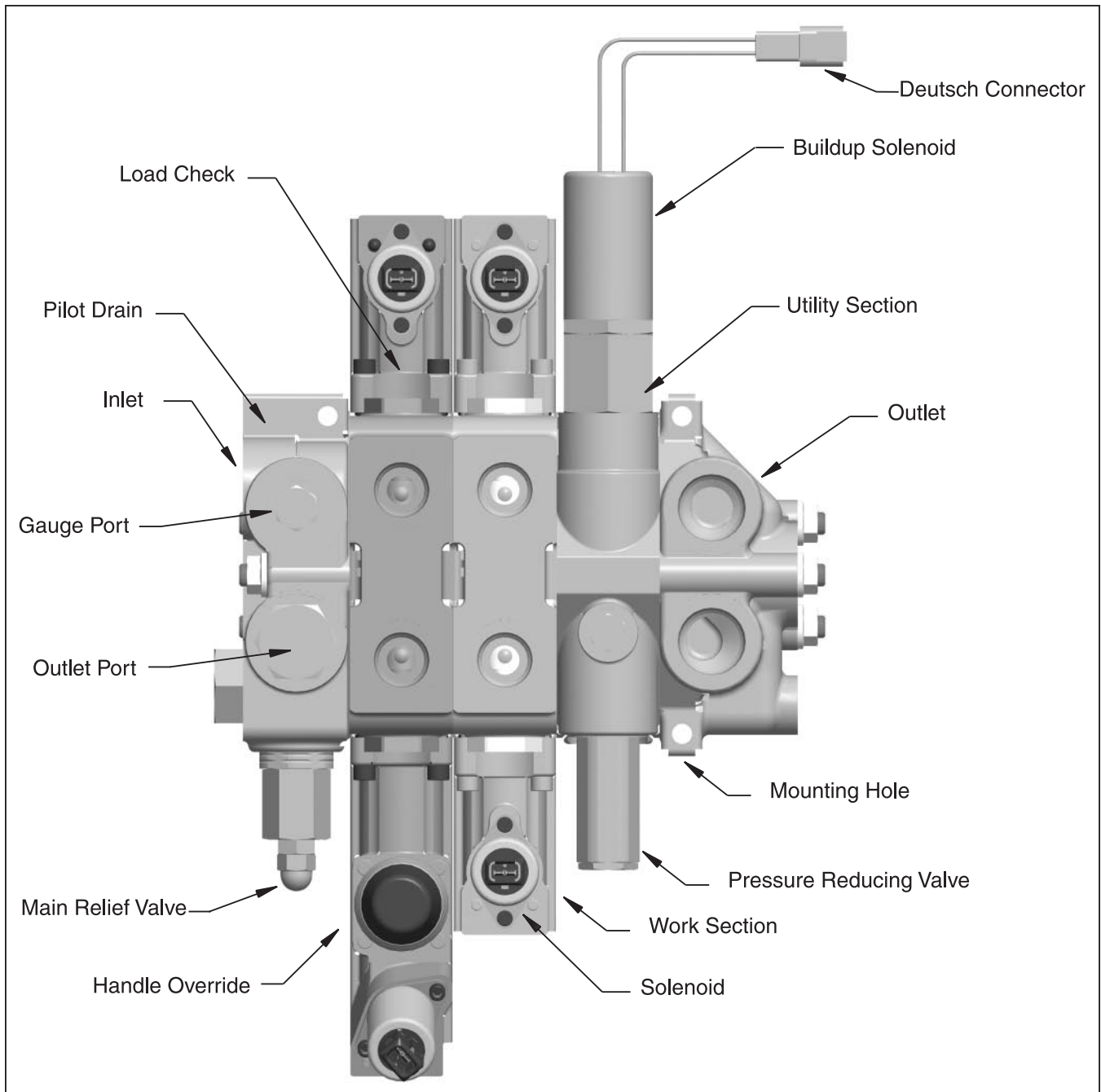

## Benefits

- The pressure required to move the spools is generated and regulated internal to the V20 valve. This eliminates the need for any in-line devices and the associated plumbing which saves installation cost.
- Minimal impact on open-center pressure drops when the main spools are in neutral. This is because pressure generation is “triggered” to on, only when a spool is selected. The benefit is less heat generation and reduced fuel consumption.
- Minimal impact on loop pressure drops: P-A/B and A/B-T which maximizes horsepower utilization.
- There is an option to have the mechanical buildup for full on-time operation, useful in many applications where the PTO is engaged only when work is to be done.
- A dedicated solenoid drain to the reservoir optimizes solenoid performance. This translates into consistent metering and machine controllability.
- An extended bonnet for screw-adjustable work port relief valves in an option available for those applications requiring this type of adjustable pressure control (consult factory).
- Handle with manual override.

### Specifications

<b>Pressures</b>	Pump Inlet Ports: 240 Bar (3500 PSI) Service Ports: 276 Bar (4000 PSI) Pilot: 35 Bar (508 PSI) (input or internal supply) Tank Return Ports: 15 Bar (220 PSI) Solenoid Drain: 2 Bar (29 PSI)
<b>Flow Rates (maximum recommended)</b>	95 LPM (25 GPM)
<b>Leakage Performance</b>	Mineral oil, 100 SUS @ 49°C (120°F) @ 69 Bar (1000 PSI) 12 cc/min with no port accessories 22 cc/min with an RV or RV & AC
<b>Hydraulic Fluid</b>	Mineral Base oil For other fluids, consult factory Viscosity, working range: 15-380mm <sup>2</sup> /s (15-380 cSt)
<b>Hydraulic Oil Temperature</b>	Recommended Operating Range without Solenoid Operation: -30° to 90°C (-22 to 194°F) Recommended Operating Range with Solenoid Operation: -20° to 80°C (-4 to 176°F)
<b>Filtration (ISO4406)</b>	20/18/14 in Main Flow Paths 18/16/13 Pilot Supply

### Weights

Inlet with relief	3.5 kg (7.8 lbs)
Work section – manual spring return	4.4 kg (9.7 lbs)
Work section – hydraulic remote	4.5 kg (9.9 lbs)
Work section – solenoid operated	6.2 kg (13.6 lbs)
Work section – pilot generation	4.1 kg (9.1 lbs)
Add for port relief	0.1 kg (0.2 lbs)
Outlet	1.5 kg (3.4 lbs)

### Solenoid Specifications

<b>Voltage</b>	12 or 24 VDC
<b>Frequency</b>	100 ±10 Hz
<b>Pilot</b>	35 Bar (508 PSI) 15-23 LPM (4-6 GPM)
<b>Current Input (I)</b>	1.5A for 12 VDC 0.75A for 24 VDC
<b>Current (mA) for Spool Shift</b>	12V    24V
<b>Start Shift</b>	400    200
<b>Full Shift</b>	1200    600
<b>Insulation Material</b>	Class H
<b>Duty Cycle</b>	100%
<b>R20 Ohm</b>	4.72 (±5%) for 12 VDC 20.82 (±5%) for 24 VDC
<b>Fluid Cleanliness</b>	17/14 per ISO 4406
<b>Ambient Temperature</b>	-30° to 80°C (-22 to 176°F)
<b>Fluid Temperature</b>	-20° to 80°C (-4 to 176°F)

### Connections

O-ring boss ports SAE-J1926-1  
BSPP ports ISO 1179-1

Description	SAE#	O-ring boss	BSPP
Inlet Port, Top or Side	12	1-1/16"-12 UNF	3/4"-14
Outlet Port, Top or Side	12	1-1/16"-12 UNF	3/4"-14
Work Ports	12	1-1/16"-12 UNF	3/4"-14
Work Ports	10	7/8"-14 UNF	1/2"-14

Inch equivalents for millimeter dimensions are shown in (\*\*)

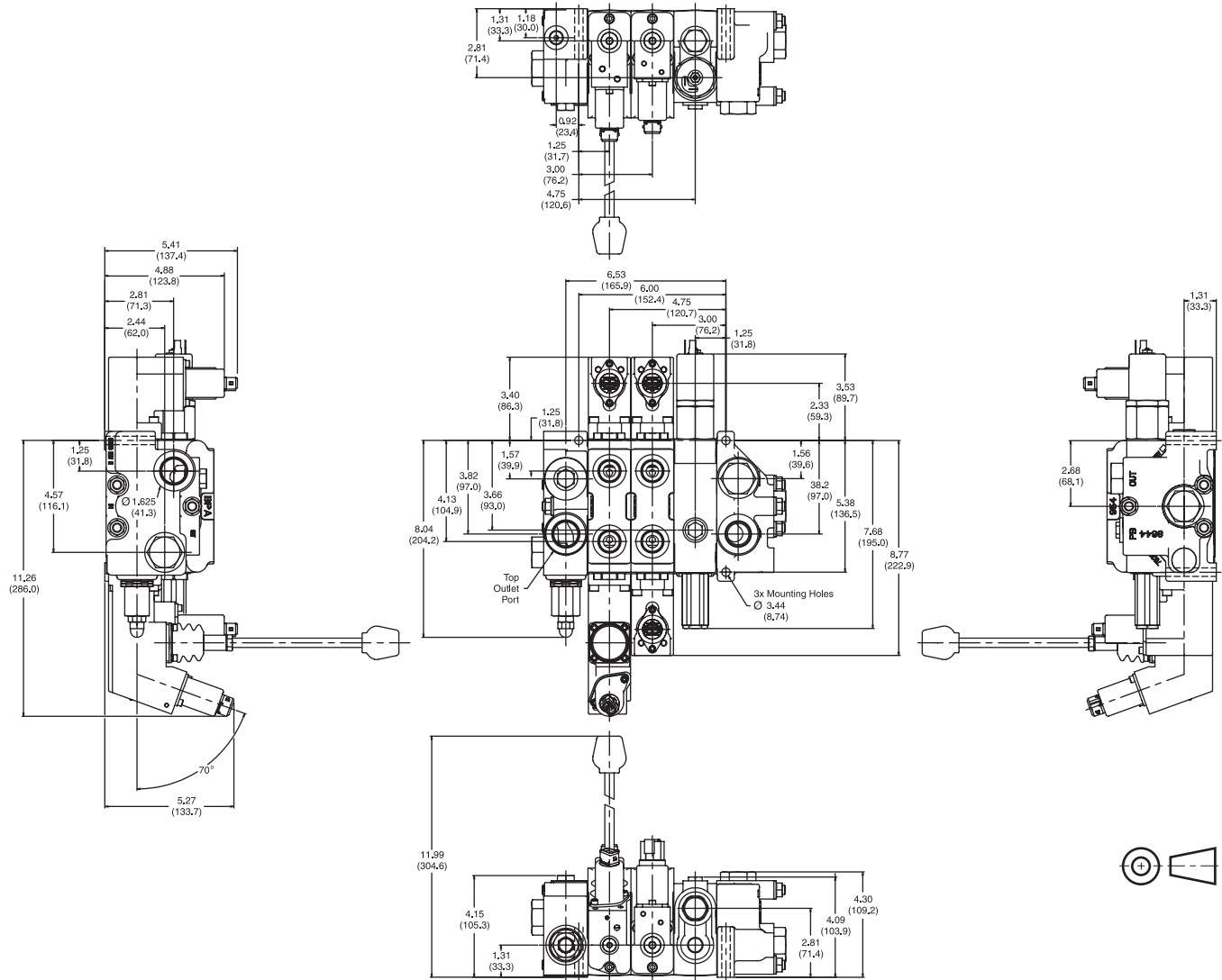

**Schematic Assembly**

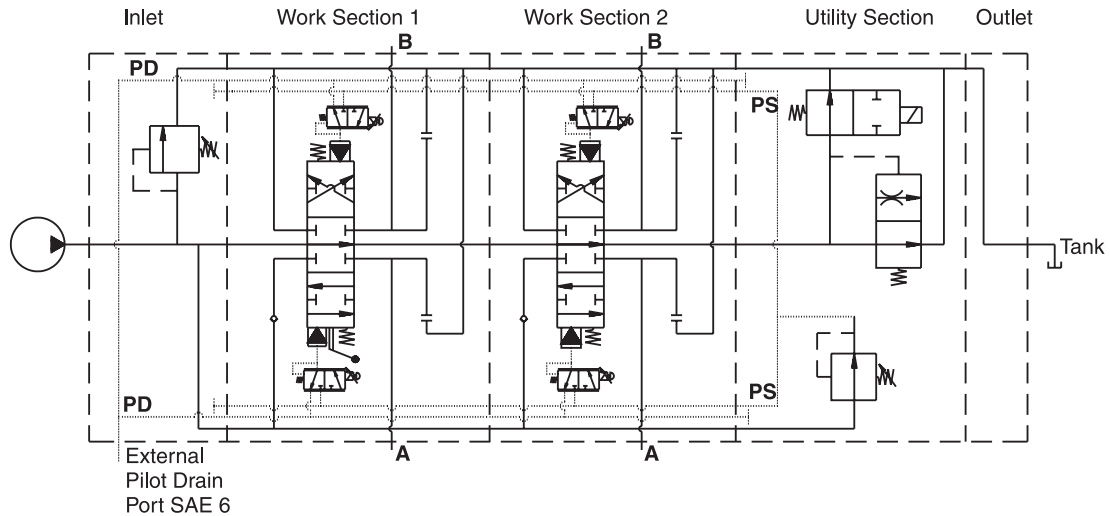

**Inlet**

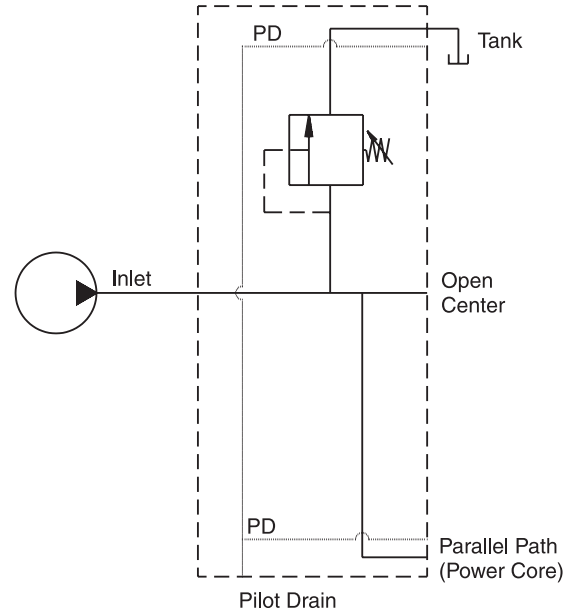
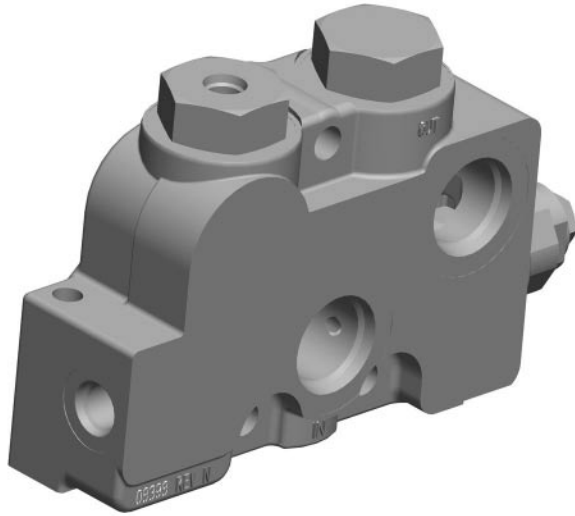

**V20 Inlet Cover (Housing 8398)**

Product Code	Side High Pressure	Side Low Pressure	Top High Pressure	Top Low Pressure	Pilot Drain
20-LC-12-EH	SAE-12	SAE-12	SAE-12	SAE-12	SAE-6

- NOTES: 1. The above inlet cover is machined to accept any of the main relief cartridges listed below.  
2. Two port plugs are furnished with each cover, one is machined with an SAE 4 port.  
3. The pilot drain port should not be tee'd into the valve's tank line, low return line pressure is required for the solenoids to operate properly.

**V20 Main Relief Valves**

Product Code	PSI Range 500-3500	PSI Range 500-1249	PSI Range 1250-1749	PSI Range 1750-1999	PSI Range 2000-2599	PSI Range 2600-3200
RP51A-3000	X					
WH-1200		X				
WH-1700			X			
WH-1950				X		
WH-2550					X	
WH-3000						X
K-20-NR	Relief Plug Kit (No Relief Option)					

- NOTES: 1. The inlet cover must have a main relief valve or a relief plug in place to operate.  
2. RP51A-3000 is a pilot operated relief valve and screw adjustable.  
3. The WH models are differential area poppet type relief valves and shim adjusted.



**Outlet**

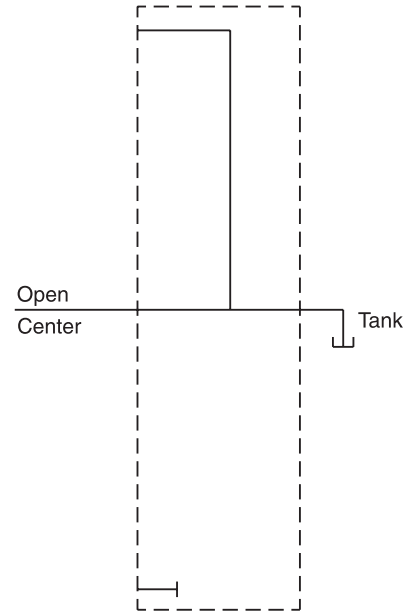
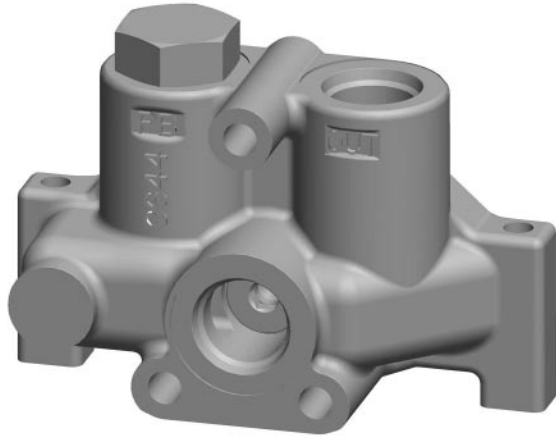

**V20 Outlet Cover (Housing 8644)**

Model Number	Side Low Pressure	Top Low Pressure
20-RC-12-EH	SAE-12	SAE-12

- NOTES: 1. Contact factory for power beyond options.  
2. The 6770 outlet housing is NOT recommended for EH banks, consult factory for details.

**V20 Section Stud Assembly Kits**

Product Code	Work Sections with Utility Section	Work Sections, Externally Piloted
K-20-EH-1	–	One Section
K-20-EH-2	One Section	Two Sections
K-20-EH-3	Two Sections	Three Sections
K-20-EH-4	Three Sections	Four Sections
K-20-EH-5	Four Sections	Five Sections
K-20-EH-6	Five Sections	Six Sections
K-20-EH-7	Six Sections	Seven Sections
K-20-EH-8	Seven Sections	Eight Sections
K-20-EH-9	Eight Sections	Nine Sections

- NOTES: 1. Kits include studs, face seals and nuts.  
2. Remember to add the utility section to the section count.  
3. Stud Torque is 28 ft-lb.

**Utility Section**

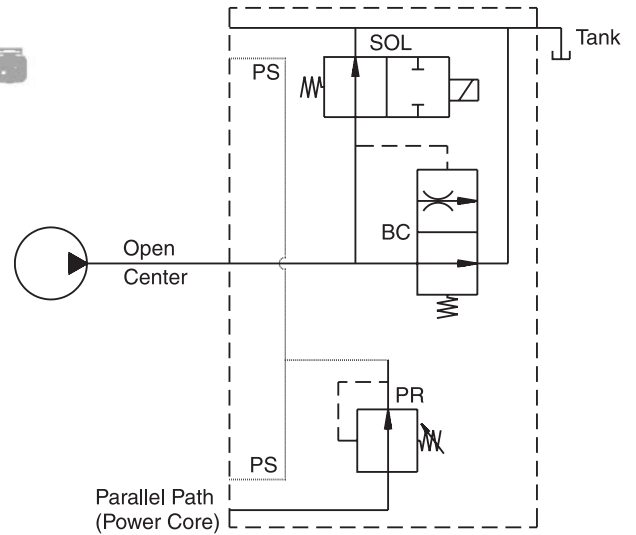
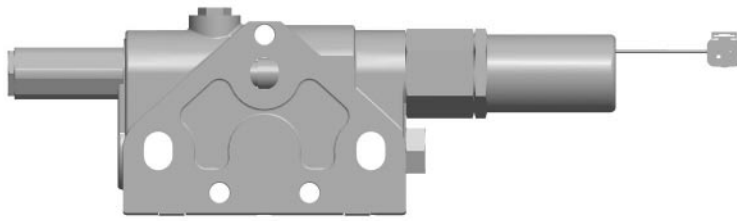

PR = Press Reducing Cartridge  
BC = Buildup Cartridge  
SOL = On/Off Solenoid  
PS = Pilot Supply

**V20 Utility Section (Housing 7820)**

Product Code	12V Solenoid See Note 3	Deutsch Connector	8 Inch Lead Wires	Always ON; Mechanical	Power Beyond	Closed-Center Systems
20-UT-EH-12	X		X			
20-UT-EH-12-D	X	X				
20-UT-EH-MECH				X		
20-UT-EH-PB					See Note 4	
20-UT-EH-CC						See Note 5
K-20-EH-EP	External Pilot Bonnet Kit. See Note 6					

- NOTES: 1. Utility Section must be stacked adjacent (upstream) to the right outlet cover.  
2. Solenoids have 6 in. lead wires terminated with Deutsch DT04-2P receptacle with pin terminals.  
3. 24V solenoids are available if your application demands it. Consult factory.  
4. For Power Beyond applications, consult factory. Ask for the application bulletin.  
5. Closed center systems, consult factory. Ask for the application bulletin.  
6. A utility section is not required when a regulated external pilot supply is available. K-20-EH-EP is a kit that incorporates two specially machined bonnets that accept the external pilot source. Each side of the bank must be fed pilot pressure for it to operate.

**Work Section, Standard**

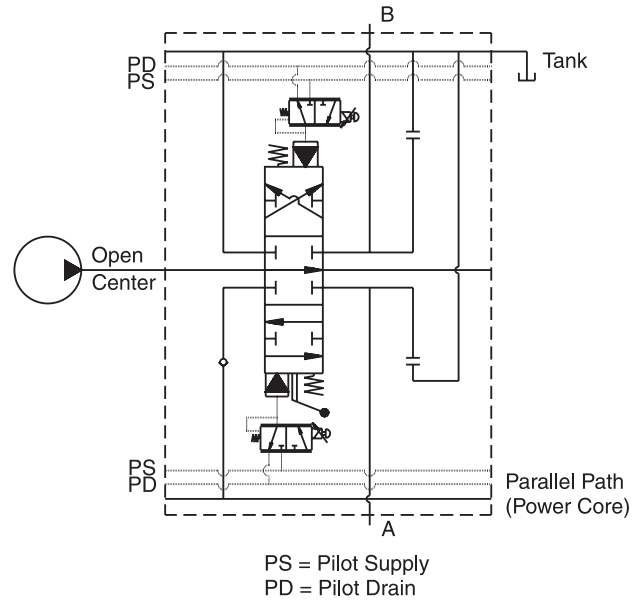
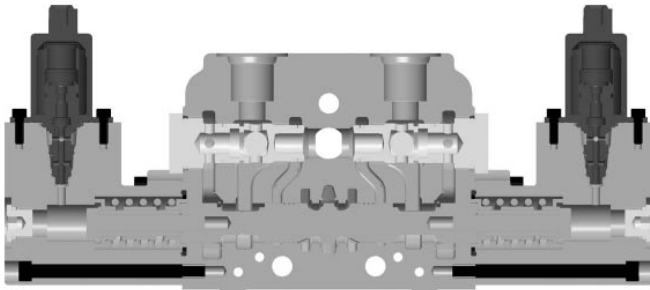

**V20 Parallel Work Sections (Housing 10954)**

Model Number	3-Way 3-Pos	4-Way 3-Pos	4-Way 3-Pos Free Flow	SAE-10 Ports	SAE-12 Ports	Amp Jr.	Amp Jr. w/Pin Override	Deutsch	12V
20-10-03-EH-12-A1	X			X		X			X
20-12-03-EH-12-A1	X				X	X			X
20-10-04-EH-12-A1		X		X		X			X
20-12-04-EH-12-A1		X			X	X			X
20-10-F4-EH-12-A1			X	X		X			X
20-12-F4-EH-12-A1			X		X	X			X
20-10-03-EH-12-A2	X			X			X		X
20-12-03-EH-12-A2	X				X		X		X
20-10-04-EH-12-A2		X		X			X		X
20-12-04-EH-12-A2		X			X		X		X
20-10-F4-EH-12-A2			X	X			X		X
20-12-F4-EH-12-A2			X		X		X		X
20-10-03-EH-12-D	X			X				X	X
20-12-03-EH-12-D	X				X			X	X
20-10-04-EH-12-D		X		X				X	X
20-12-04-EH-12-D		X			X			X	X
20-10-F4-EH-12-D			X	X				X	X
20-12-F4-EH-12-D			X		X			X	X

- NOTES: 1. These work sections can be used as ON/OFF or proportional depending on the signal input to the solenoids.  
2. For 24V applications, please consult factory.  
3. All bonnets are machined to accept the standard spool travel limiter / manual override kits.

**Work Section, Handle Override**

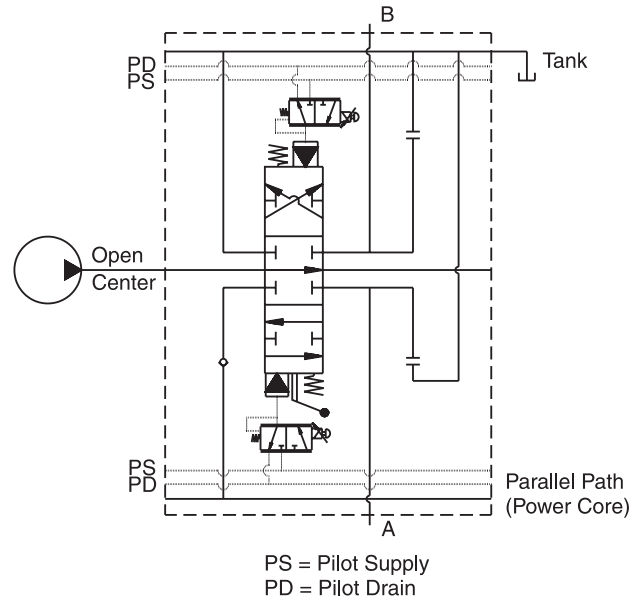
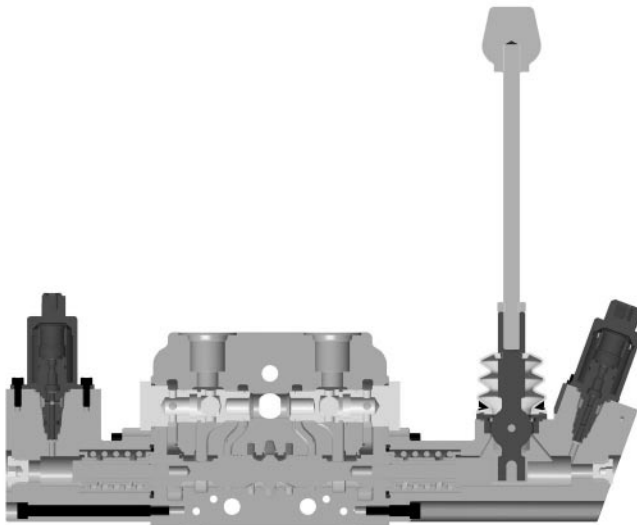

**V20 Parallel Work Sections (Housing 10954) Handle Override**

Model Number	3-Way 3-Pos	4-Way 3-Pos	4-Way 3-Pos Free Flow	SAE-10 Ports	SAE-12 Ports	Amp Jr.	Deutsch	12V Solenoid	Handle Override
20-10-03-EH-12-A1-HRO	X			X		X		X	X
20-12-03-EH-12-A1-HRO	X				X	X		X	X
20-10-04-EH-12-A1-HRO		X		X		X		X	X
20-12-04-EH-12-A1-HRO		X			X	X		X	X
20-10-F4-EH-12-A1-HRO			X	X		X		X	X
20-12-F4-EH-12-A1-HRO			X		X	X		X	X
20-10-03-EH-12-D-HRO	X			X			X	X	X
20-12-03-EH-12-D-HRO	X				X		X	X	X
20-10-04-EH-12-D-HRO		X		X			X	X	X
20-12-04-EH-12-D-HRO		X			X		X	X	X
20-10-F4-EH-12-D-HRO			X	X			X	X	X
20-12-F4-EH-12-D-HRO			X		X		X	X	X

- NOTES: 1. These work sections can be used as ON/OFF or proportional depending on the signal input to the solenoids.  
 2. For 24V applications, please consult factory.  
 3. Spool travel limiter / manual override kits are available for these sections. The handle side is different, consult the accessories page.

**Work Section, Single Ended**

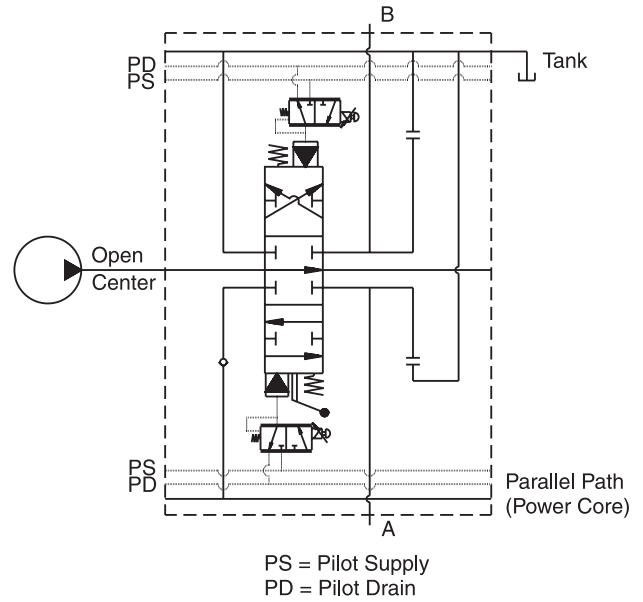
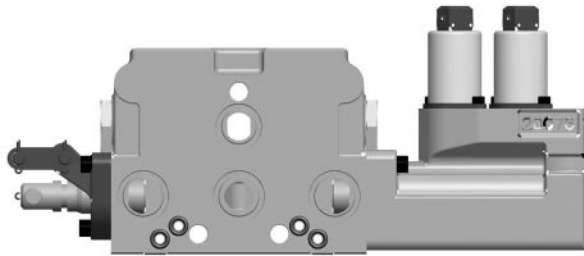

**V20 Parallel Work Sections (Housing 10954) Single Ended**

Model Number	3-Way 3-Pos	4-Way 3-Pos	4-Way 3-Pos Free Flow	SAE-10 Ports	SAE-12 Ports	Amp Jr.	Deutsch	12V Solenoid	Single Ended Actuator
20-10-03-EH-12-A1-SE	X			X		X		X	X
20-12-03-EH-12-A1-SE	X				X	X		X	X
20-10-04-EH-12-A1-SE		X		X		X		X	X
20-12-04-EH-12-A1-SE		X			X	X		X	X
20-10-F4-EH-12-A1-SE			X	X		X		X	X
20-12-F4-EH-12-A1-SE			X		X	X		X	X
20-10-03-EH-12-D-SE	X			X			X	X	X
20-12-03-EH-12-D-SE	X				X		X	X	X
20-10-04-EH-12-D-SE		X		X			X	X	X
20-12-04-EH-12-D-SE		X			X		X	X	X
20-10-F4-EH-12-D-SE			X	X			X	X	X
20-12-F4-EH-12-D-SE			X		X		X	X	X

- NOTES: 1. These work sections can only be used as ON/OFF.  
2. The standard clevis and handle bracket are present on the front side of the valve.  
3. For 24V applications, please consult factory.

**Mid-Inlets**

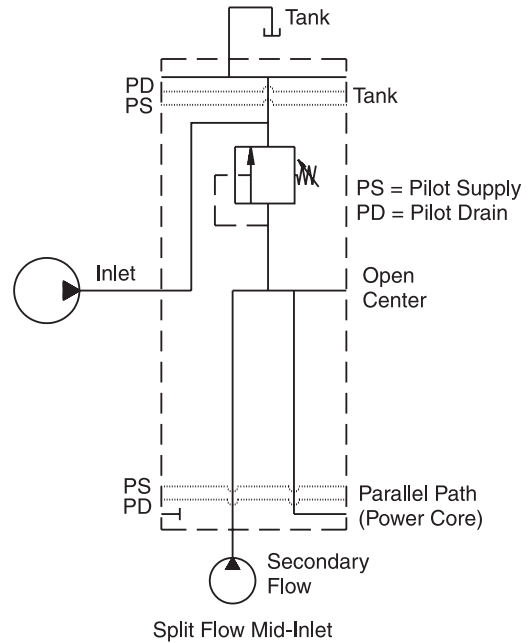
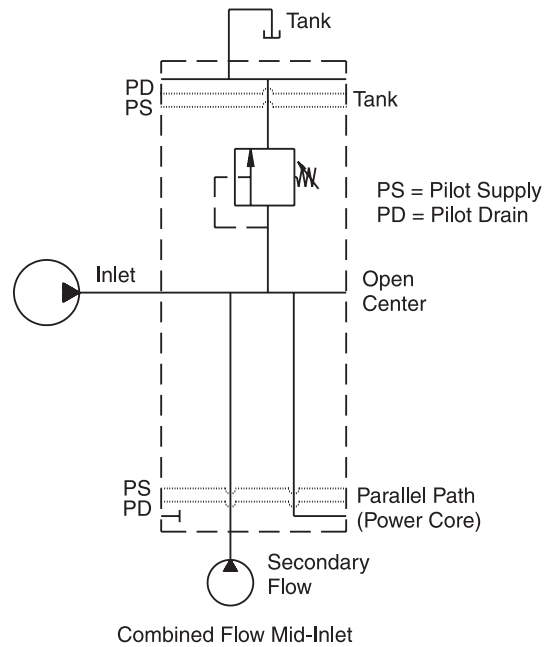
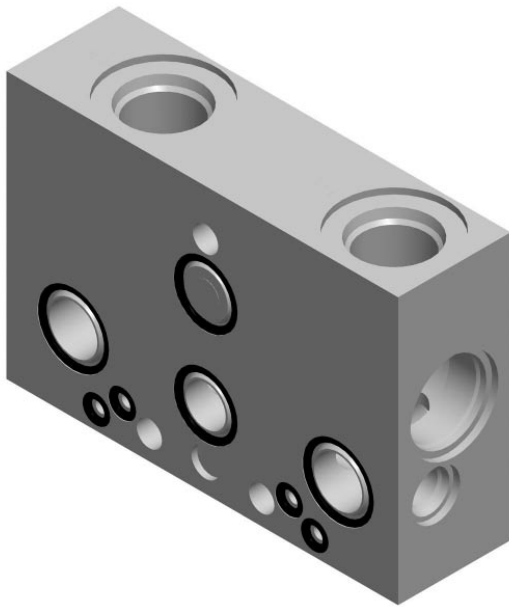

Product Code	Split Flow	Combined Flow	SAE-12	Main Relief Port
20-12-SF-EH	X		X	X
20-12-CF-EH		X	X	X

NOTE: 1. These mid-inlets are machined to accept any of the main relief cartridges listed.

### V20 Solenoids



Product Code	12V	24V	Amp Jr.	Amp Jr. w/Manual Override	Deutsch
20-EH-12-A1	X		X		
20-EH-12-A2	X			X	
20-EH-12-D	X				X
20-EH-24-A1		X	X		
20-EH-24-A2		X		X	
20-EH-24-D		X			X

K-20-A1-LW	Amp Jr. connector with 8 inch long lead wires
------------	---

### V20 Accessories

Solenoid End Cap Spool Travel Limiter and Spool Overrides

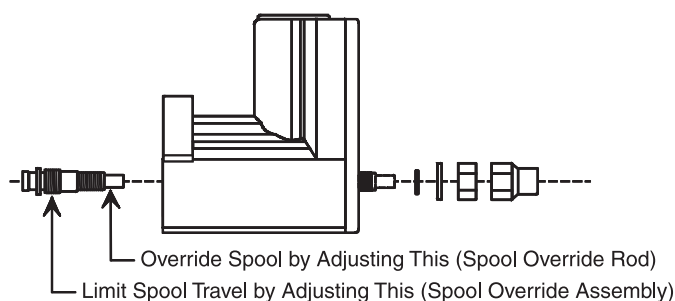

K-20-TL-MO-S	Screw type travel limiter/manual override. 1
K-20-TL-IH	Screw type travel limiter/manual override for Handle Override Sections. 1,2
K-20-EH-EP	External pilot bonnet kit.3
K-20-CONT-ON	Utility Section Mechanical Pressure Control cartridge.
K-20-12-CNTRL	Utility Section 12V Pressure Control cartridge.
K-20-24-CNTRL	Utility Section 24V Pressure Control cartridge.

- NOTES: 1. These override kits will not fit into the Single Ended (SE) sections.  
2. Use this kit for the Handle Override side of the valve only, use K-20-TL-MO-S for the opposite side.  
3. Two bonnets are included in this kit.

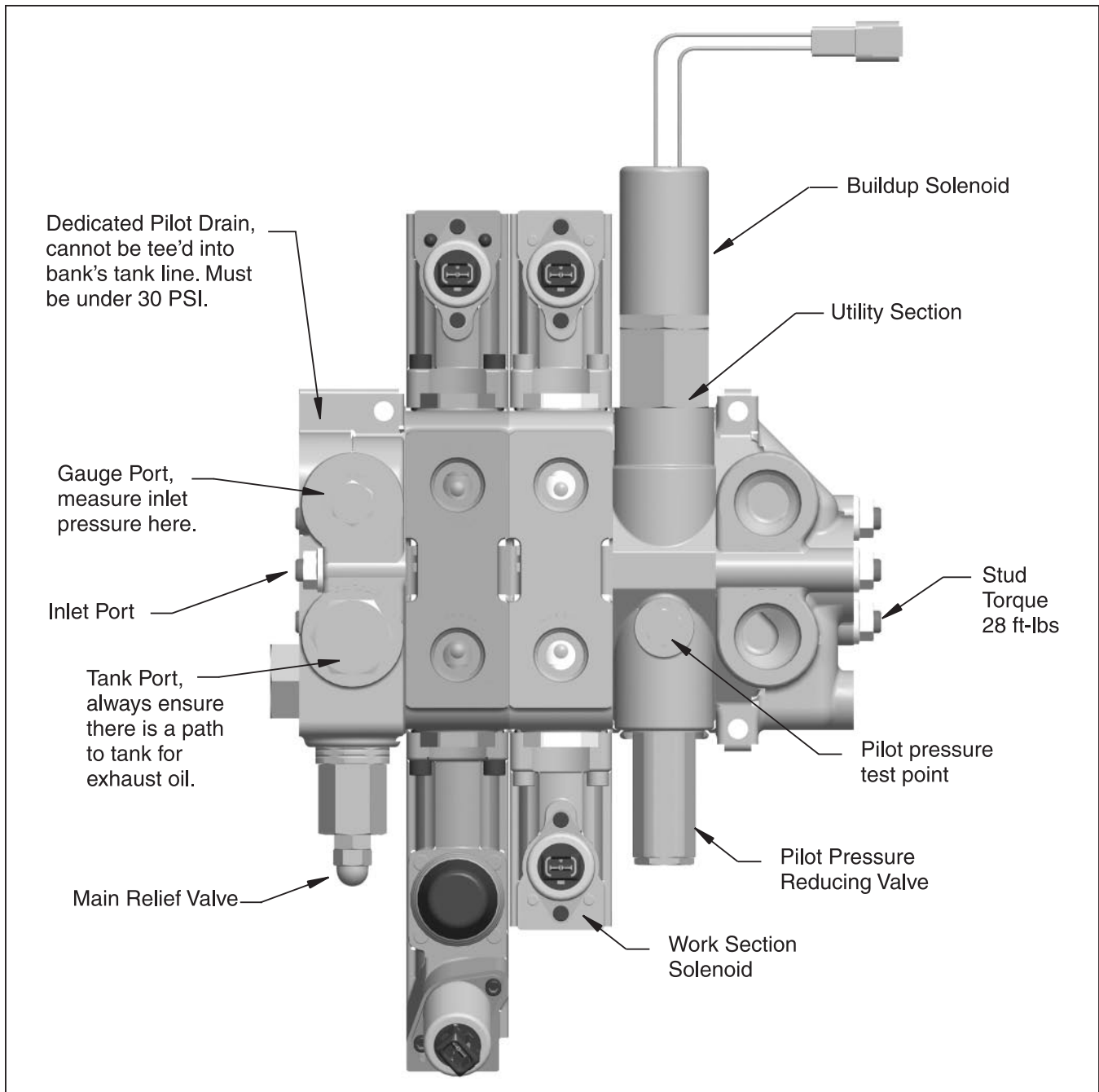

## Operation

- Ensure that the bank's outlet is connected to a tank line.
- Oil from the pump will enter the valve through the inlet, travel through the open center until it reaches the utility section and exit the valve with low pressure rise if the buildup solenoid is not on.
- Once the buildup solenoid is triggered, the open center path will be blocked and oil will be forced over the buildup cartridge.
- This action will increase the inlet pressure to approximately 400 PSI. This pressure can be checked in the inlet casting on the top port.
- The oil will then flow through the pressure reducing cartridge to feed the pilot lines.
- Pilot pressure will be approximately 300 PSI and it can be checked on the top port on the utility section.
- Ensure that the dedicated pilot drain is plumbed to a low pressure tank line and not tee'd into the bank's tank.
- The work sections are now ready to be actuated through the solenoids.



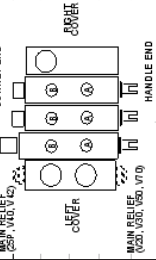

PARKER HANNIFIN CORPORATION, HYDRAULIC VALVE DIVISION						EH DIRECTIONAL CONTROL VALVE FORM			PAGE 1 OF 1	
LEFT	COVER	SECTION	#1	#2	#3	#4	#5	#6	RIGHT COVER	PORT SIZE
HSG. #	PORT SIZE:	HSG. #							HSG. #	
INLET:	PARALLEL	PARALLEL							OUTLET:	TOP
TOP	TANDEM	TANDEM							END	
END	SERIES	SERIES								
TOP	PORT SIZE:	MID-INLET (C/F&S/F)								
END		RELIEF / NR. PLUG								
		SPOOL								
		3-WAY								
		4-WAY								
		4-WAY FREE/FLOW								
		4-WAY 4-POS FLOAT								
<b>MAIN RELIEF</b>										
N-R										
PSI										
FLOW GPM										
CRACK										
<b>HANDLE</b>	"A&B" PORT	<b>POSITIONER</b>								
LCHA		STANDARD EH								
CVHA		HANDLE OVR EH								
CHHA		SINGLE ENDED EH								
BRACKET										
ENCL.		<b>SOLENOIDS</b>								
HBO		VOLTAGE								
LHO		CONNECTOR								
BOOT		PUSHPIN OVERRIDE								
WIPER		"B" PORT SIZE								
H.D. RET.		RELIEF/ANTI-CAV/N-R								
SPECIAL		PSI								
		GPM (CRACK OR F.F)								
		"A" PORT SIZE								
		RELIEF/ANTI-CAV/N-R								
		PSI								
		GPM (CRACK OR F.F)								
		FUNCTION:								
		<b>REMARKS:</b>								
										
										
		<b>VE #</b>								
		SYSTEM								
		OPERAT:								
		MAX:								
		PSI								
		GPM								
		<b>CUSTOMER:</b>								
		MODEL:								
		BOM:								

## Terms of Sale with Warranty Limitations

### Offer of Sale

The items described in this document and other documents or descriptions provided by Parker Hannifin Corporation, its subsidiaries and its authorized distributors are hereby offered for sale at prices to be established by Parker Hannifin Corporation, its subsidiaries and its authorized distributors. This offer and its acceptance by any customer ("Buyer") shall be governed by all of the following Terms and Conditions. Buyer's order for any such items, when communicated to Parker Hannifin Corporation, its subsidiary or an authorized distributor ("Seller") verbally or in writing, shall constitute acceptance of this offer.

**1. Terms and Conditions of Sale:** All descriptions, quotations, proposals, offers, acknowledgments, acceptances and sales of Seller's products are subject to and shall be governed exclusively by the terms and conditions stated herein. Buyer's acceptance of any offer to sell is limited to these terms and conditions. Any terms or conditions in addition to, or inconsistent with those stated herein, proposed by Buyer in any acceptance of an offer by Seller, are hereby objected to. No such additional, different or inconsistent terms and conditions shall become part of the contract between Buyer and Seller unless expressly accepted in writing by Seller. Seller's acceptance of any offer to purchase by Buyer is expressly conditional upon Buyer's assent to all the terms and conditions stated herein, including any terms in addition to, or inconsistent with those contained in Buyer's offer. Acceptance of Seller's products shall in all events constitute such assent.

**2. Payment:** Payment shall be made by Buyer net 30 days from the date of delivery of the items purchased hereunder. Amounts not timely paid shall bear interest at the maximum rate permitted by law for each month or portion thereof that the Buyer is late in making payment. Any claims by Buyer for omissions or shortages in a shipment shall be waived unless Seller receives notice thereof within 30 days after Buyer's receipt of the shipment.

**3. Delivery:** Unless otherwise provided on the face hereof, delivery shall be made F.O.B. Seller's plant. Regardless of the method of delivery, however, risk of loss shall pass to Buyer upon Seller's delivery to a carrier. Any delivery dates shown are approximate only and Seller shall have no liability for any delays in delivery.

**4. Warranty:** Seller warrants that the items sold hereunder shall be free from defects in material or workmanship for a period of 18 months from date of shipment from Parker Hannifin Corporation. **THIS WARRANTY COMPRISES THE SOLE AND ENTIRE WARRANTY PERTAINING TO ITEMS PROVIDED HEREUNDER. SELLER MAKES NO OTHER WARRANTY, GUARANTEE, OR REPRESENTATION OF ANY KIND WHATSOEVER. ALL OTHER WARRANTIES, INCLUDING BUT NOT LIMITED TO, MERCHANTABILITY AND FITNESS FOR PURPOSE, WHETHER EXPRESS, IMPLIED, OR ARISING BY OPERATION OF LAW, TRADE USAGE, OR COURSE OF DEALING ARE HEREBY DISCLAIMED. NOTWITHSTANDING THE FOREGOING, THERE ARE NO WARRANTIES WHATSOEVER ON ITEMS BUILT OR ACQUIRED WHOLLY OR PARTIALLY, TO BUYER'S DESIGNS OR SPECIFICATIONS.**

**5. Limitation Of Remedy: SELLER'S LIABILITY ARISING FROM OR IN ANY WAY CONNECTED WITH THE ITEMS SOLD OR THIS CONTRACT SHALL BE LIMITED EXCLUSIVELY TO REPAIR OR REPLACEMENT OF THE ITEMS SOLD OR REFUND OF THE PURCHASE PRICE PAID BY BUYER, AT SELLER'S SOLE OPTION. IN NO EVENT SHALL SELLER BE LIABLE FOR ANY INCIDENTAL, CONSEQUENTIAL OR SPECIAL DAMAGES OF ANY KIND OR NATURE WHATSOEVER, INCLUDING BUT NOT LIMITED TO LOST PROFITS ARISING FROM OR IN ANY WAY CONNECTED WITH THIS AGREEMENT OR ITEMS SOLD HEREUNDER, WHETHER ALLEGED TO ARISE FROM BREACH OF CONTRACT, EXPRESS OR IMPLIED WARRANTY, OR IN TORT, INCLUDING WITHOUT LIMITATION, NEGLIGENCE, FAILURE TO WARN OR STRICT LIABILITY.**

**6. Changes, Reschedules and Cancellations:** Buyer may request to modify the designs or specifications for the items sold hereunder as well as the quantities and delivery dates thereof, or may request to cancel all or part of this order, however, no such requested modification or cancellation shall become part of the contract between Buyer and Seller unless accepted by Seller in a written amendment to this Agreement. Acceptance of any such requested modification or cancellation shall be at Seller's discretion, and shall be upon such terms and conditions as Seller may require.

**7. Special Tooling:** A tooling charge may be imposed for any special tooling, including without limitation, dies, fixtures, molds and patterns, acquired to manufacture items sold pursuant to this contract. Such special tooling shall be and remain Seller's property notwithstanding payment of any charges by Buyer. In no event will Buyer acquire any interest in apparatus belonging to Seller which is utilized in the manufacture of the items sold hereunder, even if such apparatus has been specially converted or adapted for such manufacture and notwithstanding any charges paid by Buyer. Unless otherwise agreed, Seller shall have the right to alter,

discard or otherwise dispose of any special tooling or other property in its sole discretion at any time.

**8. Buyer's Property:** Any designs, tools, patterns, materials, drawings, confidential information or equipment furnished by Buyer or any other items which become Buyer's property, may be considered obsolete and may be destroyed by Seller after two (2) consecutive years have elapsed without Buyer placing an order for the items which are manufactured using such property. Seller shall not be responsible for any loss or damage to such property while it is in Seller's possession or control.

**9. Taxes:** Unless otherwise indicated on the face hereof, all prices and charges are exclusive of excise, sales, use, property, occupational or like taxes which may be imposed by any taxing authority upon the manufacture, sale or delivery of the items sold hereunder. If any such taxes must be paid by Seller or if Seller is liable for the collection of such tax, the amount thereof shall be in addition to the amounts for the items sold. Buyer agrees to pay all such taxes or to reimburse Seller therefore upon receipt of its invoice. If Buyer claims exemption from any sales, use or other tax imposed by any taxing authority, Buyer shall save Seller harmless from and against any such tax, together with any interest or penalties thereon which may be assessed if the items are held to be taxable.

**10. Indemnity For Infringement of Intellectual Property Rights:** Seller shall have no liability for infringement of any patents, trademarks, copyrights, trade dress, trade secrets or similar rights except as provided in this Part 10. Seller will defend and indemnify Buyer against allegations of infringement of U.S. Patents, U.S. Trademarks, copyrights, trade dress and trade secrets (hereinafter 'Intellectual Property Rights'). Seller will defend at its expense and will pay the cost of any settlement or damages awarded in an action brought against Buyer based on an allegation that an item sold pursuant to this contract infringes the Intellectual Property Rights of a third party. Seller's obligation to defend and indemnify Buyer is contingent on Buyer notifying Seller within ten (10) days after Buyer becomes aware of such allegations of infringement, and Seller having sole control over the defense of any allegations or actions including all negotiations for settlement or compromise. If an item sold hereunder is subject to a claim that it infringes the Intellectual Property Rights of a third party, Seller may, at its sole expense and option, procure for Buyer the right to continue using said item, replace or modify said item so as to make it noninfringing, or offer to accept return of said item and return the purchase price less a reasonable allowance for depreciation. Notwithstanding the foregoing, Seller shall have no liability for claims of infringement based on information provided by Buyer, or directed to items delivered hereunder for which the designs are specified in whole or part by Buyer, or infringements resulting from the modification, combination or use in a system of any item sold hereunder. The foregoing provisions of this Part 10 shall constitute Seller's sole and exclusive liability and Buyer's sole and exclusive remedy for infringement of Intellectual Property Rights.

If a claim is based on information provided by Buyer or if the design for an item delivered hereunder is specified in whole or in part by Buyer, Buyer shall defend and indemnify Seller for all costs, expenses or judgments resulting from any claim that such item infringes any patent, trademark, copyright, trade dress, trade secret or any similar right.

**11. Force Majeure:** Seller does not assume the risk of and shall not be liable for delay or failure to perform any of Seller's obligations by reason of circumstances beyond the reasonable control of Seller (hereinafter 'Events of Force Majeure'). Events of Force Majeure shall include without limitation, accidents, acts of God, strikes or labor disputes, acts, laws, rules or regulations of any government or government agency, fires, floods, delays or failures in delivery of carriers or suppliers, shortages of materials and any other cause beyond Seller's control.

**12. Entire Agreement/Governing Law:** The terms and conditions set forth herein, together with any amendments, modifications and any different terms or conditions expressly accepted by Seller in writing, shall constitute the entire Agreement concerning the items sold, and there are no oral or other representations or agreements which pertain thereto. This Agreement shall be governed in all respects by the law of the State of Ohio. No actions arising out of the sale of the items sold hereunder or this Agreement may be brought by either party more than two (2) years after the cause of action accrues.

9/91-P



## Parker Safety Guide for Selecting and Using Hydraulic Valves and Related Accessories

**WARNING:** Failure or improper selection or improper use of Parker Hydraulic Valve Division (HVD) Valves or related accessories (“Products”) can cause death, personal injury and property damage. Possible consequences of failure or improper use of these Products include but are not limited to:

- Valves or parts thereof thrown off at high speed
- High velocity fluid discharge
- Explosion or burning of the conveyed fluid
- Contact with suddenly moving or falling objects controlled by the Valve
- Injections by high-pressure fluid discharge
- Contact with fluid that may be hot, cold, toxic or otherwise injurious
- Injuries resulting from injection, inhalation or exposure to fluids
- Injury from handling a heavy item (dropped, awkward lift)
- Electric shock from improper handling of solenoid connections
- Injury from slip or fall on spilled or leaked fluid

Before selecting or using any of these Products, it is important that you read and follow the instructions below. In general, the Products are not approved for in-flight aerospace applications. Consult the factory for the few that are FAA approved.

### 1.0 GENERAL INSTRUCTIONS

- 1.1 **Scope:** This safety guide provides instructions for selecting and using (including assembling, installing and maintaining) these Products. For convenience all items in this guide are called “Valves”. This safety guide is a supplement to and is to be used in conjunction with the specific Parker catalogs for the specific Valves and/or accessories being considered for use. See item 1.6 below for obtaining those catalogs.
- 1.2 **Fail-Safe:** Valves can and do fail without warning for many reasons. Design all systems and equipment in a fail-safe mode, so that failure of the Valve or Valve Assembly will not endanger persons or property.
- 1.3 **Safety Devices:** Never disconnect, override, circumvent or otherwise disable any safety lockout on any system whether powered by HVD Valves or any motion control system of any manufacturer. (e.g. Automatic shut-off on a riding lawn mower should the operator get out of the seat).
- 1.4 **Distribution:** Provide a copy of this safety guide to each person that is responsible for selecting or using HVD Valve Products. Do not select HVD Valves without thoroughly reading and understanding this safety guide as well as the specific Parker catalogs for the Products considered or selected.
- 1.5 **User Responsibility:** Due the wide variety of operating conditions and applications for Valves, HVD and its distributors do not represent or warrant that any particular Valve is suitable for any specific system. This safety guide does not analyze all technical parameters that must be considered in selecting a product. The user, through its own analysis and testing is solely responsible for:
  - Making the final selection of the Valve
  - Assuring that the user’s requirements are met and that the application presents no health or safety hazards.
  - Providing all appropriate health and safety warnings on the equipment on which the Valves are used.
  - Assuring compliance with all applicable government and industry standards.
- 1.6 **Additional Questions:** Call the appropriate Parker technical service department if you have any questions or require any additional information. See the Parker publication for the product being considered or used, or call 1-800-CPARKER, or go to [www.parker.com](http://www.parker.com), for the telephone numbers of the appropriate technical service department. For additional copies of this or any other Parker Safety Guide go to [www.parker.com](http://www.parker.com) and click on the safety button on the opening page. Catalogs and/or catalog numbers for the various HVD Valve Products can be obtained by calling HVD at 440-366-5100. Phone numbers and catalog information is also available on the Parker website, [www.parker.com](http://www.parker.com).

### 2.0 VALVE SELECTION INSTRUCTIONS

- 2.1 **Pressure:** Valve selection must be made so that the maximum working pressure of the Valve is equal to or greater than the maximum system pressure. Surge, impulse or peak transient pressures in the system must be below the maximum working pressure of the Valve. Surge, impulse and peak pressures can usually be determined by sensitive electrical instrumentation that measures and indicates pressures at millisecond intervals. Mechanical pressure gauges indicate only average pressure and cannot be used to determine surge, impulse or peak transient pressures. Burst pressure ratings if given or known are for manufacturing purposes only and are not an indication that the Product can be used in applications at the burst pressure or otherwise above the maximum working pressure.
- 2.2 **Temperature:** The fluid temperature must be regulated or controlled so that the operating viscosity of the fluid is maintained at a level specified for the particular Valve product. Such ranges are given in the product catalogs or can be obtained from the appropriate customer service department for the particular Valve product.
- 2.3 **Fluid Compatibility:** The fluid conveyed in Valves has direct implications on the Valve selection. The fluid must be chemically compatible with the Valve component materials. Elastomer seals, brass, cast iron, aluminum for example all are potentially affected by certain fluids. Additionally, fluid selection affects the performance of various Valves. Considerations relative to fluid selection are outlined in the specific HVD Valve product catalog. Of particular importance is that the fluid be for hydraulic use, contain the proper additives and wear inhibitors. See 1.6 “Additional Questions” above for information to obtain such HVD catalogs.
- 2.4 **Changing Fluids:** If a system requires a different fluid, it should be done with the guidance in number 2.3 above. Additionally, it may be necessary to flush the system (including the Valves) to remove any of the previous fluid. Consult the Parker Valve Division for guidance.
- 2.5 **Size:** Transmission of power by means of pressurized fluid varies with pressure and rate of flow. The size of the components must be adequate to keep pressure losses to a minimum and avoid damage due to heat generation or excessive fluid velocity.
- 2.6 **Placement:** Installation of Valves must take into account the orientation of the Valve and the proximity of the Valve to other parts of the system. This includes but is not limited to closeness to hot and cold areas, access for servicing and operation as well as orientation for proper connectors.
- 2.7 **Ports:** Connection of Valves in systems can be by threaded ports, sub-base surfaces, flanges and manifolds. In all cases, the proper fitting, surface or mounting hardware must be selected to properly seal and contain the system fluid so as to avoid the adverse conditions listed in the initial warning box above. Specifically, if using threaded ports, the designer must make sure that the mating fitting is of the compatible thread. Also, the instructions provided by the connector hardware supplier must be read and understood so as to properly assemble the connector. The Parker Safety Guide for using Hose, Tubing and Fittings and Related Accessories is but one reference to this end.
- 2.8 **Environment:** Care must be taken to insure that the Valve and Valve Assemblies are either compatible with or protected from the environment (that is, surrounding conditions) to which they are exposed. Environmental conditions including but not limited to ultraviolet radiation, sunlight, heat, ozone, moisture, water, salt water, chemicals and air pollutants can cause degradation and premature failure.
- 2.9 **Electric Power:** For Valves requiring electric power for control, it is imperative that the electricity be delivered at the proper voltage, current and wattage requirements. To obtain the proper control requirements please refer to the respective Parker product catalog for the specific Valve that is intended for use. If further guidance is required, call the appropriate technical service department identified in the respective Parker product catalog.
- 2.10 **Specifications and Standards:** When selecting Valves, government, industry and Parker specifications and recommendations must be reviewed and followed as applicable.
- 2.11 **Accessories:** All accessories used in conjunction with any Parker Valve product must be rated to the same requirements of the Valve including but not limited to pressure, flow, material compatibility, power requirements. All of these items must be examined as stated in the “VALVE INSTALLATION INSTRUCTIONS” paragraph 3.0.

(continued on next page)



### 3.0 **VALVE INSTALLATION INSTRUCTIONS**

- 3.1 **Component Inspection:** Prior to use, a careful examination of the Valve(s) must be performed. The Valve intended for use must be checked for correct style, size, catalog number and external condition. The Valve must be examined for cleanliness, absence of external defects or gouges, cracked or otherwise deformed parts or missing items. The mounting surface or port connections must be protected and free of burrs, scratches, corrosion or other imperfections. Do NOT use any item that displays any signs of nonconformance. In addition, any accessory including but not limited to fittings, bolt kits, hoses, sub bases, manifolds, and electrical connectors must be subjected to the same examination.
- 3.2 **Handling Valves:** Many Valves whether HVD Valves or of another manufacturer can be large, bulky or otherwise difficult to handle. Care must be taken to use proper lifting techniques, tools, braces, lifting belts or other aids so as not to cause injury to the user, any other person or to property.
- 3.3 **Filtration:** Fluid cleanliness is a necessity in any hydraulic system. Fluid filters must be installed and maintained in the system to provide the required level of fluid cleanliness. Filters can be placed in the inlets, pressure lines and return lines. The level of cleanliness required is specified in the HVD product catalog for the specific Valve(s) selected or intended for use. For additional information on Filter selection contact Parker Filter Division at 800-253-1258 or 419-644-4311.
- 3.4 **Servo Valves:** Application of Servo Valves in general requires knowledge and awareness of “closed loop control theory” and the use of electronic controls for successful and safe operation. Individuals who do not have such experience or knowledge must gain training before use of such Products. Parker offers both classroom training as well as manuals to assist in gaining this knowledge. These aids can be obtained by contacting Hydraulic Valve Division at 440-366-5100, calling the general Parker help line 800-CPARKER or going to the Parker web site at [www.parker.com](http://www.parker.com).
- 3.5 **Accessory Ratings:** All accessories used in combination with the selected or intended Valve product must be rated and compatible with the selected Valve. Specifically, the items must be of equal or greater rating including but not limited to pressure, flow, power, size, port style, thread connectors and material.
- 3.6 **Connection Styles:** It is the responsibility of the user of the Parker product to properly select connectors and accessories that match the connections on the sub plate, Valve, flange or threaded connection or manifold. It is also the responsibility of the installer to possess adequate skill and knowledge including but not limited to thread preparation, torque technique, hose assembly and inspection, tube preparation and assembly, and fitting installation. Parker Tube Fitting Division ([www.parker.com/tfd](http://www.parker.com/tfd)) catalog 4300 and Parker Hose Products ([www.parkerhose.com](http://www.parkerhose.com)) catalog 4400 describe some basic technical information relative to proper fitting assembly.
- 3.7 **Electrical Connections:** All electrical connections must be made to the applicable codes and local safety requirements.
- 3.8 **Gauges and Sensors:** The user must install sufficient gauges and sensors in the system so as to be able to determine the condition of the system. This includes but is not limited to pressure gauges, flow meters, temperature sensors and site gauges. These are of utmost importance should removal or disassembly of a Valve, portion of a Valve or portion of the system become necessary. Refer to “VALVE MAINTENANCE AND REPLACEMENT INSTRUCTIONS” for details and especially item 4.8.
- 3.9 **System Checkout:** Once installed, the Valve installation must be tested to insure proper operation and that no external leakage exists. All safety equipment must be in place including but not limited to safety glasses, helmets, ear protection, splash guards, gloves, coveralls and any shields on the equipment. All air entrapment must be eliminated and the system pressurized to the maximum system pressure (at or below the Valve maximum working pressure) and checked for proper function and freedom from leaks. Personnel must stay out of potentially hazardous areas while testing and using.

### 4.0 **VALVE MAINTENANCE AND REPLACEMENT INSTRUCTIONS**

- 4.1 **Maintenance Program:** Even with proper installation, Valves and Valve System life may be significantly reduced without a continuing maintenance program. The severity of the application and risk potential must determine the frequency of the inspection and the replacement of the Products so that Products are replaced before any failure occurs. A maintenance program must be established and followed by the user and, at a minimum, must include instructions 4.2 through 4.10. An FMEA (Failure Mode and Effects Analysis) is recommended in determining maintenance requirements.
- 4.2 **Visual Inspection-Valves:** Any of the following conditions require immediate shut down and replacement of the Valve.
- Evidence that the Valve is in partial dis-assembly.
  - Visible crack or suspicion of a crack in the Valve housing or bent, cracked or otherwise damaged solenoid.
  - Missing or partially extending drive pin on a flow control knob.
  - Missing, loose components, obstructions or other condition impeding the motion or function of the manual knob, lever, foot pedal or other mechanical operator of a hydraulic Valve.
  - Any evidence of burning or heat induced discoloration.
  - Blistered, soft, degraded or loose cover of any kind.
  - Loose wire or electrical connector.
- 4.3 **Visual Inspection-Other:** The following conditions must be tightened, repaired, corrected or replaced as required.
1. Fluid on the ground must be cleaned immediately. Also, the source of the fluid must be determined prior to running the equipment again.
  2. Leaking port or excessive external dirt build-up.
  3. System fluid level is too low or air is entrapped or visible in the reservoir.
  4. Equipment controlled by the Valve or Valve assembly has been losing power, speed, efficiency
- 4.4 **Filter Maintenance:** System filters must be maintained and kept in proper working order. The main service requirement is periodic replacement of the filter element or screen. Contact Parker Filter Division at 800-253-1258 or 419-644-4311 for further filter maintenance details.
- 4.5 **Functional Test:** See “System Checkout” number 3.9 above in “VALVE INSTALLATION INSTRUCTIONS”.
- 4.6 **Replacement Intervals:** Valves and Valve Systems will eventually age and require replacement. Seals especially should be inspected and replaced at specific replacement intervals based on previous experience, government or industry recommendations, or when failures could result in unacceptable downtime, damage or injury risk. At a minimum seals must be replaced whenever service is rendered to a Valve product.
- 4.7 **Adjustments, Control Knobs, and Other Manual Controls:** System Pressure and Flow are typically adjusted by knobs and/or handles. A set-screw or lock-nut secures the adjustment device so as to maintain the desired setting. This set-screw or lock-nut must first be loosened prior to making any adjustments and re-tightened after adjustment on the HVD Valve. All adjustments must be made in conjunction with pressure gauges and/or flow meters (or by watching the speed of the actuator in the case of setting flow only). See paragraph “Gauges and Sensors” above in the section “VALVE INSTALLATION INSTRUCTIONS”. Under no circumstances should any control knob, adjustment stem, handle, foot pedal or other actuating device be forced beyond the mechanical stop(s) on the Valve. For example, the Parker Safety Notice Bulletin **HY14-3310-B1/US** for HVD Colorflow Valves specifically restricts the adjustment torque to “hand adjust” or “less than 10 ft/lbs” if it cannot be adjusted by hand. Failure to adhere to this may force the knob beyond the stop point allowing it to be ejected at high speed resulting in death, personal injury and property damage. For complete safety instructions on HVD Colorflow Valves, copies of Safety Notice **Bulletin HY14-3310-B1/US** can be obtained directly from the Hydraulic Valve Division at 440-366-5100 or from the Parker web site at [www.parker.com](http://www.parker.com) by selecting the “Safety” button. Parker help line 800-CPARKER is on call 24/7 as well should there be any question about the use of a HVD Valve. Additionally, when making adjustments, always adjust the Valve with all parts of your body to the side of the Valve (that is, the knob is not pointing toward you or anyone else).
- 4.8 **High pressure Warning:** Hydraulic power is transmitted by high-pressure fluids through hoses, fittings and valves, pumps and actuators. This condition can be dangerous and potentially lethal and, therefore, extreme caution must be exercised when working with fluids under pressure. From time to time, hoses, Valves, tubes or fittings fail if they are not replaced at proper time intervals. Typically these failures are the result of some form of misapplication, abuse, wear, or failure to perform proper maintenance. When such failure occurs, generally the high pressure fluid inside escapes in a stream which may or may not be visible to the user. Under no circumstances should the user attempt to locate the leak by “feeling” with their hands or any other part of their body. High-pressure fluids can and will penetrate the skin and cause severe tissue damage and possible loss of limb or life. Even seemingly minor hydraulic fluid injection injuries must be treated immediately by a physician with knowledge of the tissue damaging properties of hydraulic fluid.
- If a hose, tube, fitting or Valve failure occurs, immediately shut down the equipment and leave the area until pressure has been completely released from the system. Simply shutting down the pump may or may not eliminate the pressure in the system. It may take several minutes or even hours for the pressure to be relieved so that the leak area can be examined safely. Once the pressure has been reduced to zero, the suspected leaking item can be taken off the equipment and examined. It must always be replaced if a failure has occurred. Never attempt to patch or repair a connector (especially a hose) or Valve that has failed. Consult the nearest Parker distributor or the appropriate Parker division for component replacement information. Never touch or examine a failed hydraulic component unless it is obvious that the item no longer contains fluid under pressure.

## Parker Hydraulics International Sales Offices

### North America

#### Motion & Control Division – Montreal

2001 rue de l'aviation  
Dorval, Quebec, H9P 2X6  
Tel: 514-684-3000  
Fax: 514-684-4191

#### Motion & Control Division – Calgary

3141B – 16th Street N.E.  
Calgary, Alberta T2E 7K8  
Tel: 403-291-9284  
Fax: 403-291-9285

#### Mexico

#### Parker Hannifin de Mexico, S.A. C.V

Via de Ferrocarril a Matamoros 730  
Apodaca, N.L. C.P. 66600, Mexico  
Tel: 01-8181-566036 y 96

### Europe

#### Austria

**Parker Hannifin GmbH**  
Badener Strasse 12  
AT-2700 Wiener Neustadt, Austria  
Tel: 43 2622-23501 970  
Fax: 43 2622-23501 977

#### Belarus

**Parker Hannifin Corporation**  
Pr. Nezavisimosti, 11, Office 524  
BY-220030 Minsk, Belarus  
Tel: 375 17 209 9399  
Fax: 375 17 209 9227

#### Belgium

**Parker Hannifin SA NV**  
ZI Sud 2  
23, Rue du Bosquet  
BE-1400 Nivelles, Belgium  
Tel: 32 67 280 900  
Fax: 32 67 280 999

#### Czech Republic/Slovakia

**Parker Hannifin s.r.o.**  
Parkerova 623  
CZ-250 67 Klecany, Czech Republic  
Tel: 420 284 083 111  
Fax: 420 284 083 112

#### Denmark

**Parker Hannifin Denmark A/S**  
Industriparken 35-37  
DK-2750 Ballerup, Denmark  
Tel: 45 43 56 04 00  
Fax: 45 43 73 31 07

#### Finland

**Parker Hannifin Oy**  
Ylästöntie 16  
FI-01520 Vantaa, Finland  
Tel: 358 20 753 2500  
Fax: 358 20 753 2200

### Europe

#### France

**Parker Hannifin France SAS**  
142, rue de la Forêt  
FR-741 30 Contamine sur Arve, France  
Tel: 33 4-50 25 80 25  
Fax: 33 4-50 03 67 37

#### Germany/Switzerland

**Parker Hannifin GmbH & Co. KG**  
Pat-Parker-Platz 1  
DE-41564 Kaarst, Germany  
Tel: 49 (0) 2131 4016 0  
Fax: 49 (0) 2131 4016 9199

#### Greece

**Parker Hannifin Corporation**  
197 Syngrou Av.  
GR-171 21 Athens, Greece  
Tel: 0030 210 933-6450  
Fax: 0030 210 933-6451

#### Hungary

**Parker Hannifin Corporation**  
**Hungarian Trade Representative Office**  
Egressy u. 100  
HU-1149 Budapest, Hungary  
Tel: 36 1 220 4155  
Fax: 36 1 422 1525

#### Ireland

**Parker Hannifin Ireland Ltd**  
Baldonnell Business Park  
Baldonnell, Naas Road  
IE-Co. Dublin, Ireland  
Tel: 353 (0)1 466 63 70  
Fax 353 (0)1 466 63 76

#### Italy

**Parker Hannifin SpA**  
Via Privata Archimede 1  
IT-200 94 Corsico (MI), Italy  
Tel: 39 02-45 19 21  
Fax: 39 02-44 79 340

#### Latvia (Lithuania, Kaliningrad)

**Parker Hannifin Corporation**  
79A Slokas Street, Office No. 6  
LV-1007 Riga, Latvia  
Tel: 371 74 52 601  
FAX: 371 74 52 608

#### The Netherlands

**Parker Hannifin BV**  
Edisonstraat 1  
NL-7575 AT Oldenzaal, The Netherlands  
Tel: 31 541 585 000  
Fax: 31 541 585 459

#### Norway

**Parker Hannifin A/S**  
Berghagan  
PO Box 3008  
NO-1402 Ski, Norway  
Tel: 47 64-91 10 00  
Fax: 47 64-91 10 90

### Europe

#### Poland

**Parker Hannifin Sp.zo.o**  
ul. Równolegla 8  
PL-02-435 Warszawa, Poland  
Tel: 48 22 573 24 00  
Fax: 48 22 573 24 03

#### Portugal

**Parker Hannifin Portugal, Lda**  
Travessa da Bataria 184 R/C  
Dto./1 Esq.  
PT-4450-625 Leça da Palmeira, Portugal  
Tel: 351 22 999 7360  
Fax: 351 22 996 1527

#### Romania

**Hidro Consulting Impex SRL**  
Bld Ferdinand nr 27, Sect 2  
RO-021381 Bucharest, Romania  
Tel: 40 21 252 13 82  
Fax: 40 21 252 33 81

#### Russia

**Moscow**  
**Parker Hannifin LLC**  
8-go Marta str., 6A, build 1  
RU-127083 Moscow, Russia  
Tel: 7 495 645 21 56  
Fax: 7 495 612 18 60

#### Sakhalin

**Parker Hannifin LLC**  
**Branch Office Sakhalin**  
Pr. Mira 1  
RU-693012 Yuzhno-Sakhalinsk, Russia  
Tel: 7 4242 42 35 27  
Fax: 7 4242 42 35 27

#### Ukraine

**Parker Hannifin Corporation**  
**Representation Office in Ukraine**  
vul. Velyka Vasylykivska 9/2 Office 59  
UA-01004 Kyiv, Ukraine  
Tel: 380 44 494 2731/2732/2724  
Fax: 380 44 494 2730

#### Azerbaijan

**Parker Hannifin plc**  
**Azpar, Technical Representative**  
140 Alovzat Guliyev St. Apt. 10  
AZ-1000 Baku, Azerbaijan  
Tel: 99 412 598 3966  
Fax: 99 412 598 3966

#### Kazakhstan

**Parker Hannifin**  
**Gateway Ventures CA Ltd,**  
**Representative**  
7A Kabanbai Batira  
KZ-480100 Alamy, Kazakhstan  
Tel: 7 3272 505 800  
Fax: 7 3272 505 801

(continued on next page)

04/08

## Parker Hydraulics International Sales Offices

---

### Europe

#### Slovenia

**Parker Hannifin Corporation**  
Vel. Bucna vas 7  
SI-8000 Novo mesto, Slovenia  
Tel: 386 7 337 6650  
Fax: 386 7 337 6651

#### Spain

**Parker Hannifin España SA**  
P.O. Box No. 74  
P. I. Las Monjas, c/Estaciones, 8  
ES-28850 Torrejón de Ardoz  
Madrid, Spain  
Tel: 34 91-675 73 00  
Fax: 34 91-675 77 11

#### Sweden

**Parker Hannifin AB**  
Fagerstagatan 51  
Box 8314  
SE-163 08 Spånga, Sweden  
Tel: 46 8 5979 50 00  
Fax: 46 8 5979 51 10

#### Parker Hannifin AB

Almenåsvägen 22  
SE-501 78 Borås, Sweden  
Tel: 46 33 700 52 00  
Fax: 46 33 13 89 40

#### Turkey

**Parker Hannifin Corporation**  
**Liaison Office of Turkey**  
Merter Is Merkezi  
Gen. Ali Rıza Gurcan cad. No: 2 / 67  
TR-34067 Merter/Istanbul, Turkey  
Tel: 90 212 482 91 06/07  
Fax: 90 212 482 91 10

#### United Kingdom

**Parker Hannifin Ltd**  
Tachbrook Park Drive  
Tachbrook Park  
UK-Warwick, CV34 6 TU, England  
Tel: 44 1926 317 878  
Fax: 44 1926 317 855

### Asia Pacific

#### China

**Parker Tejing**  
**Hydraulic Tianjin**  
21 Hongyuan Road  
Xiqing Development Zone  
CN-Tianjin 300385, China  
Tel: 86 22 5838 8899  
Fax: 86 22 5838 8917

#### India

**Parker Hannifin India Pvt Ltd**  
Plot No. EL-26, MIDC, TTC Industrial Area  
Mahape,  
IN-Navi Mumbai 400 709, India  
Tel: 91 22 5613 7081/7082/7083/7084  
Fax: 91 22 2768 6841/6618

#### Japan

**Parker Hannifin Japan Ltd**  
Shirokanedai Building 2nd Floor  
3-2-10, Shirokanedai, Minato-ku  
JP-Tokyo, 108-0071, Japan  
Tel: 81 3 6408 3900  
Fax: 81 3 5449 7201

#### Malaysia

**Parker Hannifin Singapore Pte Ltd**  
**(Malaysia Branch Office)**  
Lot 558A, Jalan Subang 3  
Off Persiaran Subang  
Sungai Penaga Industrial Park  
MY-47610 Subang Jaya, Malaysia  
Tel: 60 (0)3 5638 1476  
Fax: 60 (3)3 5638 1527

#### New Zealand

**Parker Hannifin (N.Z.) Ltd**  
3 Bowden Road  
Mt. Wellington, Auckland, New Zealand  
Tel: 64 9 574 1744  
Fax: 64 9 573 1529

#### Singapore

**Parker Hannifin Singapore Pte Ltd**  
No. 11 Fourth Chin Bee Road  
SG-Singapore 619702,  
Republic of Singapore  
Tel: 65 6887 6300  
Fax: 65 6265 5125

### Asia Pacific

#### Taiwan

**Parker Hannifin Taiwan Co., Ltd**  
No. 40, Wuchuan 3rd Rd.,  
Wuku Industrial Park  
Taipei County, Taiwan 248, R.O.C.  
Tel: 886 2 2298 8987  
Fax: 886 2 2298 8982

#### Thailand

**Parker Hannifin Thailand Co., Ltd**  
1023, 3rd floor, TPS building  
Pattanakarn Road, Suanluang  
Bangkok 10250, Thailand  
Tel: 662 717 8140  
Fax: 662 717 8148

### Latin America

#### Argentina

**Parker Hannifin Argentina SAIC**  
Stephenson 2711 esq. Costa Rica  
1667 Tortuguitas  
Buenos Aires, Argentina  
Tel: 54 3327 44 4129  
Fax: 54 3327 44 4199

#### Chile

**Parker Hannifin Chile Ltda**  
Av. Americo Vespucio 2760-E  
Conchali - Santiago, Chile  
Tel: 56-2-623-1216  
Fax: 56-2-623-1421

#### Venezuela

**Parker Hannifin de Venezuela, SA**  
Av. Principal con calle Miraima  
Edificio Draza, Boleita Norte  
Caracas, Venezuela  
Tel: 58 212 238 5422  
Fax: 58 212 239 2272







**Notes**

---

# Extensive Hydraulic Product Offering

## Accumulators



*Piston, bladder and diaphragm type accumulators, gas bottles and KleenVent reservoir isolators.*

[www.parker.com/accumulator](http://www.parker.com/accumulator)

## Compact Hydraulics



*Self-contained with a motor, gear pump, reservoir, internal valving, load hold checks and relief valves.*

[www.parker.com/oildyne](http://www.parker.com/oildyne)

## Cylinders



*Standard and custom hydraulic cylinders for industrial and mobile applications.*

[www.parker.com/hydcyl](http://www.parker.com/hydcyl)

## Electronics/Remote Controls



*Parker's unique IQAN approach combines sturdy, well-tested hardware with intelligent, flexible computing power.*

[www.parker.com/iqan](http://www.parker.com/iqan)

## Filtration



*Pressure and return line filters enhances machine life, reduces maintenance and lowers costs.*

[www.parker.com/hydraulicfilter](http://www.parker.com/hydraulicfilter)

## Integrated Hydraulic Circuits



*Solutions for complex circuits that include threaded cartridge valves integrated into a single manifold.*

[www.parker.com/ihd](http://www.parker.com/ihd)

## Motors



*Full line of high and low speed motors provides power up to 15,000 in-lbs of torque.*

[www.parker.com/pumpmotor](http://www.parker.com/pumpmotor)

## Power Take Off



*Parker Chelsea leads the industry for engineering, innovation and performance in auxiliary power systems.*

[www.parker.com/chelsea](http://www.parker.com/chelsea)

## Power Units



*The most complete line of standard, pre-engineered, cataloged hydraulic power units in the industry.*

[www.parker.com/pumpmotor](http://www.parker.com/pumpmotor)

## Pumps



*Broad line of energy-efficient hydraulic pumps that includes piston, vane and gear pumps.*

[www.parker.com/mobpump](http://www.parker.com/mobpump)

## Rotary Actuator



*Industry leader in the design and manufacture of hydraulic rack and pinion, and vane style rotary actuators.*

[www.parker.com/actuator](http://www.parker.com/actuator)

## Valves and Controls



*Hydraulic valves for virtually every hydraulic equipment application, from simple to precise control.*

[www.parker.com/hydraulicvalve](http://www.parker.com/hydraulicvalve)

*Covering the Industrial, Mobile and Truck markets, each catalog is paired with an interactive CD. Call for your comprehensive guides today. 1-800-CParker*



*Mobile Bulletin  
HY19-1001/US*

*Industrial Bulletin  
HY01-1001/US*

*Truck Bulletin  
HY19-1004/US*

# Parker Hydraulics International Sales Offices

## North America

**Hydraulics Group Headquarters**  
6035 Parkland Boulevard  
Cleveland, OH 44124-4141 USA  
Tel: 216-896-3000  
Fax: 216-896-4031

**Parker Hannifin Canada  
Motion & Control Division – Milton**  
160 Chisholm Drive Milton  
Ontario Canada L9T 3G9  
Tel: 905-693-3000  
Fax: 905-876-1958

## Mexico

**Parker Hannifin de México**  
Av eje uno norte num 100  
Parque Industrial Toluca 2000  
Toluca, Mex C.P. 50100  
Tel: 52 722 2754200  
Fax: 52 722 2799308

## Europe

**Europe Hydraulics Group  
Parker Hannifin Corporation**  
Parker House  
55 Maylands Avenue  
Hemel Hempstead, Herts  
HP2 4SJ England  
Tel: 44 1442 458000  
Fax: 44 1442 458085

## Latin America

### Brazil

**Hydraulics Division  
Parker Hannifin Ind. e Com. Ltda**  
Av. Frederico Ritter, 1100  
Cachoeirinha RS, 94930-000 Brazil  
Tel: 55 51 3470 9144  
Fax: 55 51 3470 3100

### Pan American Division

7400 NW 19th Street, Suite A  
Miami, FL 33126 USA  
Tel: 305-470-8800  
Fax: 305-470-8808

## Mobile Sales

**Mobile Sales Organization  
and Global Sales**  
595 Schelter Road  
Suite 100  
Lincolnshire, IL 60069 USA  
Tel: 847-821-1500  
Fax: 847-821-7600

## Industrial Sales

**Great Lakes Region**  
3700 Embassy Parkway  
Suite 260  
Fairlawn, OH 44333 USA  
Tel: 330-670-2680  
Fax: 330-670-2681

**Southern Region**  
1225 Old Alpharetta Road  
Suite 290  
Alpharetta, GA 30005 USA  
Tel: 770-619-9767  
Fax: 770-619-9806

**Chicago Region**  
1163 E. Ogden Avenue  
Suite 705, #358  
Naperville, IL 60563 USA  
Tel: 630-964-0796  
Fax: 866-473-9274

**Pacific Region**  
8460 Kass Drive  
Buena Park, CA 90621 USA  
Tel: 714-228-2510  
Fax: 714-228-2511

**Eastern Region**  
100 Corporate Drive  
Lebanon, NJ 08833 USA  
Tel: 908-236-4121  
Fax: 908-236-4146

**Gulf Region**  
20002 Standing Cypress Drive  
Spring, TX 77379 USA  
Tel: 317-519-8490  
Fax: 866-390-4986

## Asia Pacific

**Asia Pacific Headquarters  
Parker Hannifin Hong Kong Ltd**  
8/F, Kin Yip Plaza  
9 Cheung Yee Street  
HK-Cheung Sha Wan, Hong Kong  
Tel: 852 2428 8008  
Fax: 852 2425 6896

**Australia Headquarters  
Parker Hannifin Pty Ltd.**  
9 Carrington Road  
Castle Hill, NSW 2154, Australia  
Tel: 612 9634 7777  
Fax: 612 9842 5111

**China Headquarters  
Parker Hannifin Motion & Control  
(Shanghai) Co., Ltd**  
280 Yunqiao Road,  
Jin Qiao Export Processing Zone  
CN-Shanghai 201206, China  
Tel: 86 21 5031 2525  
Fax: 86 21 5834 3714

**Korea Headquarters  
Parker Hannifin Korea Ltd**  
6F Daehwa Plaza  
169 Samsung-dong, Gangnam-gu  
KR-Seoul, 135-090, Korea  
Tel: 82 2 559 0400  
Fax: 82 2 556 8187

## South Africa

**Parker Hannifin Africa Pty Ltd  
Parker Place**  
10 Berne Avenue Aeroport  
P.O. Box 1153  
ZA-Kempton Park 1620,  
Republic of South Africa  
Tel: 27 11 961 0700  
Fax: 27 11 392 7213

## Middle East

**Egypt  
Parker Hannifin Corporation**  
8B Zahraa Maadi  
Region 17F  
Cairo, Egypt  
Tel: (20) 2 5194018  
Fax: (20) 2 5190605



Parker Hannifin Corporation  
**Hydraulic Valve Division**  
520 Ternes Avenue  
Elyria, Ohio 44035 USA  
Tel: 440-366-5200  
Fax: 440-366-5253  
[www.parker.com/hydraulicvalve](http://www.parker.com/hydraulicvalve)

Catalog HY14-2733/US,  
1.5M, 11/08, NOP

Your Local Authorized Parker Distributor